

# MEC24 modulating fan control



READ AND SAVE THESE INSTRUCTIONS!



**Product information**

**Chapters 1 + 2**



**Mechanical installation**

**Chapter 3**



**Electrical installation**

**Chapter 4**



**Start up and configuration**

**Chapter 5**



**Maintenance and troubleshooting**

**Chapter 6**

**Job name:** \_\_\_\_\_





**Installer:** \_\_\_\_\_

**Installation date:** \_\_\_\_\_

**Distributor contact information:**  
exodraft a/s • Tel: +45 7010 2234  
info@exodraft.dk • www.exodraft.com

# Contents

2

	<b>1. Product information</b>	
	1.1 Function .....	4
	1.2 Shipping .....	4
	1.3 Warranty .....	4
	<b>2. Specifications</b>	
	2.1 Dimensions and capacities .....	5
	<b>3. Mechanical installation</b>	
	3.1 Location .....	6
	3.2 Mounting of control .....	6
	3.3 Mounting of transducer .....	7
	3.4 Mounting of stack probe .....	7
	3.5 Connecting transducer to stack probe .....	7
	<b>4. Electrical installation</b>	
	4.1 General .....	8
	4.2 Continuous chimney fan operation .....	9
	4.3 Intermittent chimney fan operation (120 V) .....	10
	4.4 Connection to a variable frequency drive .....	12
	4.5 Integrated Proven Draft Switch with external Proven Draft Switch backup .....	13
	<b>5. Startup and configuration</b>	
	5.1 General .....	14
	5.5 Basic control set-up .....	14
	5.6 Detailed control programming .....	15
	<b>6. Settings and troubleshooting</b>	
	6.1 Troubleshooting .....	16
	6.2 Settings .....	17

## Symbol legend

The following terms are used throughout this manual to bring attention to the presence of potential hazards or to important information concerning the product.



### DANGER

Indicates an imminent hazardous situation which, if not avoided, will result in death, serious injury or substantial property damage.



### CAUTION

Indicates an imminent hazardous situation which, if not avoided, may result in personal injury or property damage.



## TO REDUCE THE RISK OF FIRE, ELECTRICAL SHOCK OR INJURY TO PERSONS, OBSERVE THE FOLLOWING:

1. Use this unit in the manner intended by the manufacturer. If you have questions, contact the manufacturer's distributor at the address or telephone number listed on the front of the manual.
2. Before servicing or cleaning the unit, switch off at service panel and lock service panel to prevent power from being switched on accidentally.
3. Installation work and electrical wiring must be done by a qualified person(s) in accordance with applicable codes and standards.
4. Follow the appliance manufacturer's guidelines and safety

standards and the national authorities safety standards in the country in which the installation is taking place.

5. This unit must be grounded.

### How to use this manual

This installation manual does not contain any system design documentation. System design documentation is available from **exodraft**.

Accessories and variable frequency drives are not covered by this manual. Please refer to these component's individual manuals.

## Symboles

Les termes suivants sont utilisés dans ce manuel pour attirer l'attention sur la présence de dangers potentiels ou sur des informations importantes concernant le produit.



### DANGER

Indique une situation dangereuse imminente qui, si elle n'est pas évitée, aura pour résultat la mort, des blessures graves ou des dommages matériels considérables.



### CAUTION

Indique une situation dangereuse imminente qui, si elle n'est pas évitée, aura pour résultat des blessures ou des dommages matériels.



## AFIN DE RÉDUIRE LE RISQUE D'INCENDIE, DE CHOC ÉLECTRIQUE OU DE BLESSURES, VEUILLEZ RESPECTER LES POINTS SUIVANTS :

1. Utilisez cet appareil de la manière prévue par le fabricant. Si vous avez des questions, contactez le distributeur du fabricant à l'adresse postale ou au numéro de téléphone figurant sur le manuel.

Association (NFPA), la American Society for Heating, Refrigeration and Air Conditioning Engineers (ASHRAE), et les autorités locales.
2. Avant toute intervention de maintenance ou de nettoyage de l'appareil, le mettre hors tension au niveau du panneau de service et verrouiller le panneau de service afin d'empêcher toute mise sous tension accidentelle.
3. Les travaux d'installation et le câblage électrique doivent être effectués par une/des personne(s) qualifiée(s) conformément aux lois et normes applicables.
4. Suivez les directives du fabricant de l'appareil et les normes de sécurité telles que celles publiées par la National Fire Protection
5. L'appareil doit être mis à la terre.

Comment utiliser ce manuel

Ce manuel d'installation ne contient aucune documentation de conception du système. La documentation de conception du système est disponible à partir d'ENERVEX.

Les accessoires et variateurs de fréquence ne sont pas couverts par ce manuel. Prière de vous reporter aux manuels individuels de ces composants.

# 1. Product information

## 1.1 Function

**Use** The **exodraft** MEC24 is a Mechanical Exhaust Control used to monitor and maintain a constant pressure in a duct system. This is achieved by modulating the speed of a fan or ventilator. The MEC24 can be used with the **exodraft** models EFH, RSV and the EXHAUSTO models BESB and BESF. It can control the fan speed directly or via a Variable Frequency Drive (VFD). The MEC24 is typically used to control the pressure in duct systems serving clothes dryers, bathrooms, kitchen hoods and other building venting applications.

**Function** The control monitors the pressure in a duct system via connection to a pressure sensor (XTP) , and maintains the pressure by modulating the fan speed. The control has an integrated safety system that assures the appliance shuts down in the event of fan and/or control failure.

The use of the MEC24 is not restricted to any type of duct or venting application. When the appliance is activated, the control sends maximum voltage to the fan or VFD. Once the specified pressure is achieved, the control regulates the voltage to the fan or VFD to maintain the specified pressure (the value can be viewed on the display).

If desired, the control can be interlocked with an appliance. When the appliance is activated, the control sends maximum voltage to the fan or VFD. Once the specified pressure is achieved, the control releases the appliance for operation and continues to regulate the voltage to the fan or VFD to maintain the specified pressure (the value can be viewed in the display). In the event of insufficient pressure, the control assures the appliance(s) shuts down after 15 seconds. When the appliance shuts down, the control turns off the fan.

The control can be used in one of two ways:

- Interlocked with the appliance to pre-purge the duct prior to appliance start-up and post-purge the duct for 3 minutes after appliance shut down.
- Set to run the fan continuously.

In most cases, local codes will require continuous fan operation.

**Other functions** The control has an integrated safety function. It can be operated with a manual reset function (reset button) or an automatic reset function. All terminal connections are monitored by LED's for easy service and troubleshooting.

## 1.2 Shipping

### The MEC24 standard packing list

- MEC24 control unit
- Pressure transducer (XTP)
- Silicone tubing
- Stack probe

If other components are shipped, these will appear as separate items on the shipment packing list.

## 1.3 Warranty

**Complete warranty conditions are available from exodraft.**

# 2. Specifications

## 2.1 Dimensions and capacities

exodraft MEC24 Control		
Power supply	V	1x120 VAC / 60 Hz
Fuse Size Control/Motor	A	0.4/6.3
Max. Motor Load	kW/hp	0.35/0.5
Operating temperature	°F/°C	-4 to 122/-20 to 50
Range of operation	inWC/Pa	0-0.6/0-150
Tolerance	inWC/Pa	0.01/3+/-10%
Control signal VFD	VDC/mA	0-10/max. 10
Control and Alarm relay	Max	230 VAC/4A AC1 - 24 VDC/2A DC1
Boiler Inputs		10-48 VDC / 10-132 VAC
VFD Relay	Max	230 VAC/2A AC1 - 24VDC/2A DC1
Output TRIAC	VAC	10-120
Dimensions	A in/mm	6.88/175
	B in/mm	8.48/215
	C in/mm	4.33/110
Weight	lbs/kg	3.0/1.5
IP-Rating		NEMA 4X / IP54
Ashcroft XTP-sensor		
Power supply	VDC	14-36
Amperage	mA	6
Output	VDC	0-10
Operating temperature	°F/°C	0 to 160/-17 to 70
Tolerance	inWC/Pa	0.01/3+/-10%
Weight	lbs/kg	.9/.4
Chimney Probe		
Dimensions	H in/mm	4.25/108
	I in/mm	3.50/89

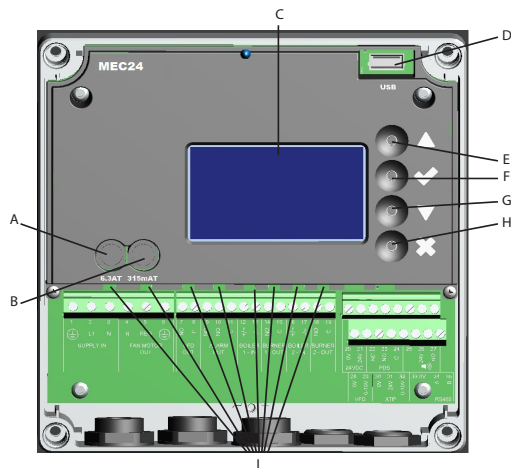
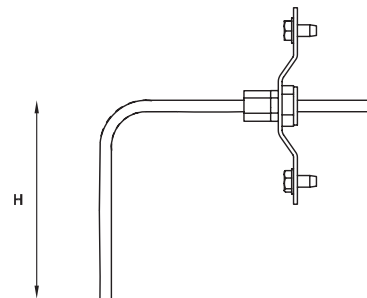
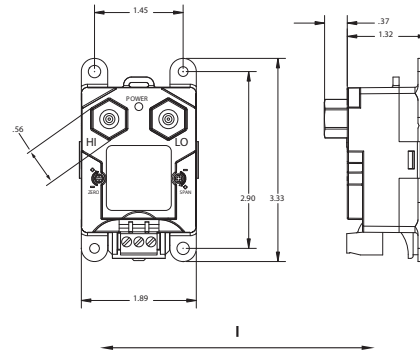
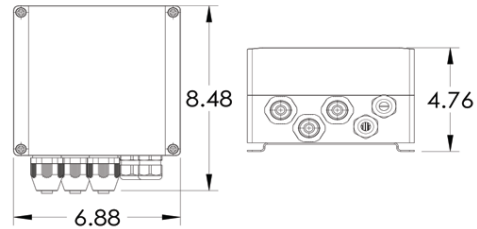

Fig. 1

### Symbols

- Fig. 1-A Fuse holder Exhaust Fan
- Fig. 1-B Fuse holder Control
- Fig. 1-C Display 128 x 64 pixels
- Fig. 1-D USB port
- Fig. 1-E Up button
- Fig. 1-F Select / Confirm button
- Fig. 1-G Down button
- Fig. 1-H Reset / Back button
- Fig. 1-I LEDs (green) showing ON/OFF status

# 3. Mechanical installation

## 3.1 Location

The control and the transducer can be installed indoors and outdoors. The control does not need to be installed in an enclosure. Fig. 2 shows how the components are connected.

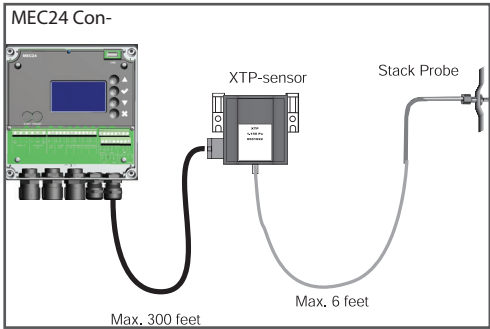

Fig. 2

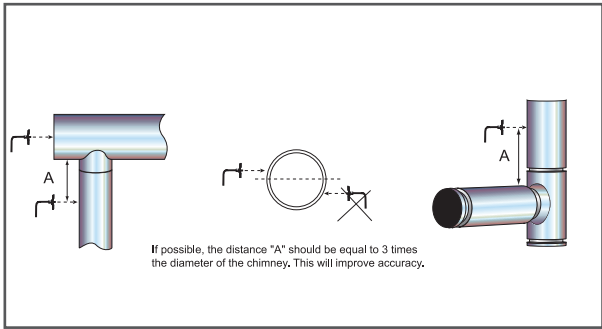

Fig. 2a



**The transducer cannot be mounted inside an airtight enclosure. It uses the boiler room pressure/atmospheric pressure as reference pressure.**

## 3.2 Mounting of control

The control can be mounted directly on a wall or similar.

- Remove the clear cover.
- The mounting holes are located under the plastic screws that hold the cover in place (Fig. 3).
- The distance between the control and the transducer should not exceed three hundred (300) feet.

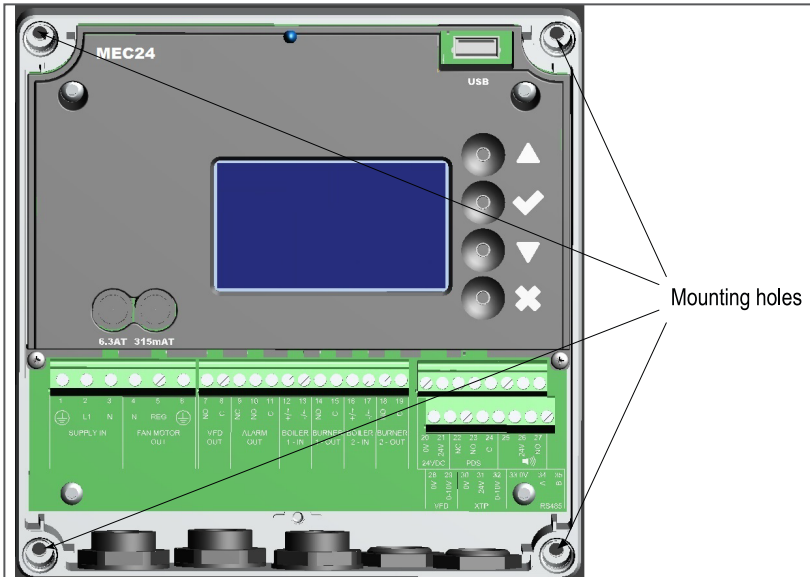
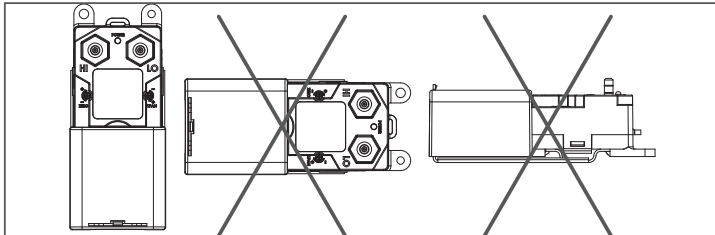

Fig. 3

### 3.3 Mounting of transducer

Attention must be paid to the position and location of the transducer. Fig. 5 shows the required position. Failure to follow this instruction may result in an inoperable system.

- An Ashcroft XTP-sensor used for sensing draft should be mounted within six (6) feet of the stack probe.
- An Ashcroft XTP-sensor used for sensing room pressure should be mounted within fifty (50) feet of the Outdoor Pressure Probe.



**Fig. 4**

### 3.4 Mounting of stack probe

The probe (Fig. 2a on page 5) is inserted into the chimney or vent at the point where the draft should be kept constant. This could be at the appliance outlet, in the vent or similar.

Referring to Fig. 2, make sure the tip of the tube is flush with the inner wall of the stack. Inserting it too far may affect the reading and thereby the operation.

### 3.5 Connecting transducer to stack probe

The transducer is connected to the stack probe via a silicone tube. Make sure that the tube is connected to the proper transducer port as shown in Fig. 5.

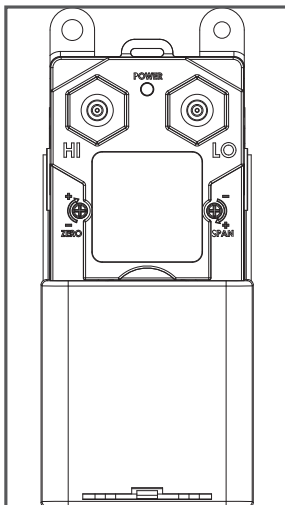

**Fig. 5**

## ⚡ 4. Electrical installation

8

### 4.1 General

#### DANGER



Turn off electrical power before servicing. Contact with live electric components can cause shock or death.

Mettre hors tension avant toute opération de maintenance. Le contact avec des composants sous tension peut entraîner un choc électrique ou la mort.

#### NOTE



EBC24 is designed for 1x120 VAC power supply only. Fan output is regulating on the phase side and cannot be connected to other circuits.

EBC24 est conçu uniquement pour une alimentation de 1x120 VCA. La sortie du ventilateur est réglée sur le côté phase et ne peut pas être connectée à d'autres circuits.

The control can be used in two ways:

- Connected so the fan runs continuously independent of appliance operation (see paragraph 4.2).
- Interlocked with an appliance so the appliance operation indirectly controls the fan operation (see paragraph 4.3).

In both cases the control will still monitor and maintain a constant draft.

There are two types of safety systems available:

- Integrated Proven Draft Switch (standard)
- Integrated Proven Draft Switch with external Proven Draft Switch (accessory) backup (see paragraph 4.4).

The terminals are connected as shown on fig. 6:

Terminal	Use	Terminal	Use
1	Power Supply-PE Ground	18	Burner 2 relay contact-Normally Open (max. 230 VAC, 4 Amps.)
2	Power Supply-L1	19	Burner 2 relay contact-Common (max. 230 VAC, 4 Amps.)
3	Power Supply-N	20	Control signal VFD 0 VDC
4	Chimney Fan-N	21	Control signal VFD 0-10 VDC
5	Chimney Fan-L1 (Regulating)	22	XTP-0 VDC Power Supply (transducer)
6	Chimney Fan-PE Ground	23	XTP-24 VDC Power Supply (transducer)
7	VFD Relay NO	24	XTP-0-10 VDC Return Signal (transducer)
8	VFD Relay C	25	RS485 0V
9	Alarm Out-NC	26	RS485 A
10	Alarm Out-NO	27	RS485 B
11	Alarm Out-C	28	0VDC Power Supply
12	Voltage Input from Appliance / Boiler 1 thermostat Optocoupler (+) (10-230 VAC/DC)	29	24 VDC Power Supply (Max 100 mA)
13	Voltage Input from Appliance/Boiler 1 thermostat Optocoupler (-) (10-230 VAC/DC)	30	PDS-NC (Normally Closed) Proven Draft Switch
14	Burner 1 relay contact-Normally Open (max. 230 VAC, 4 Amps.)	31	PDS-NO (Normally Open) Proven Draft Switch
15	Burner 1 relay contact-Common (max. 230 VAC, 4 Amps.)	32	PDS-C (Common) Proven Draft Switch
16	Voltage Input from Appliance / Boiler 2 thermostat Optocoupler (+) (10-230 VAC/DC)	33	Buzzer-24 VDC Supply
17	Voltage Input from Appliance / Boiler2 thermostat Optocoupler (-) (10-230 VAC/DC)	34	Not used
		35	Buzzer Signal

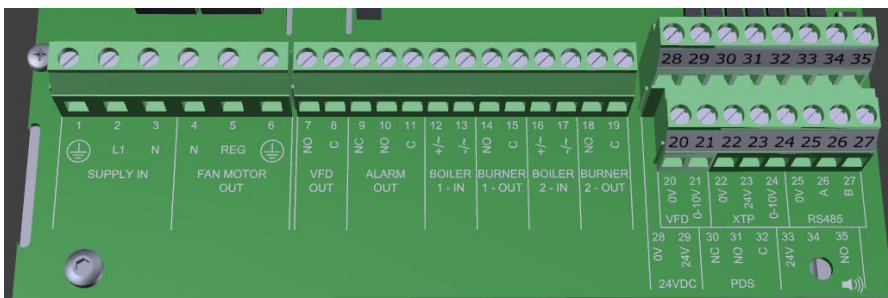

Fig. 6



## 4.2 Continuous chimney fan operation

Fig. 7 shows how to connect a chimney fan to the MEC24 if continuous operation is needed:

- Connect the power supply to terminals 1, 2 and 3.
- Jump terminals 13 and 28.
- Jump terminals 12 and 29
- Jump terminals 30 and 32
- Connection to the appliance(s):
  - ▶ Connect the start signal from the burner to terminals 14 and 15.
- To connect the chimney fan:
  - ▶ If using a 1x120V chimney fan, connect it to terminals 4, 5 and 6. Refer to the fan's Installation Manual.
  - ▶ If using a 3-phase fan and VFD, connect the VFD to terminals 20 and 21 as shown in Fig. 10 and 11. **DO NOT** connect the fan directly to the MEC24 control.
- Connect the XTP transducer to terminals 22, 23 and 24.

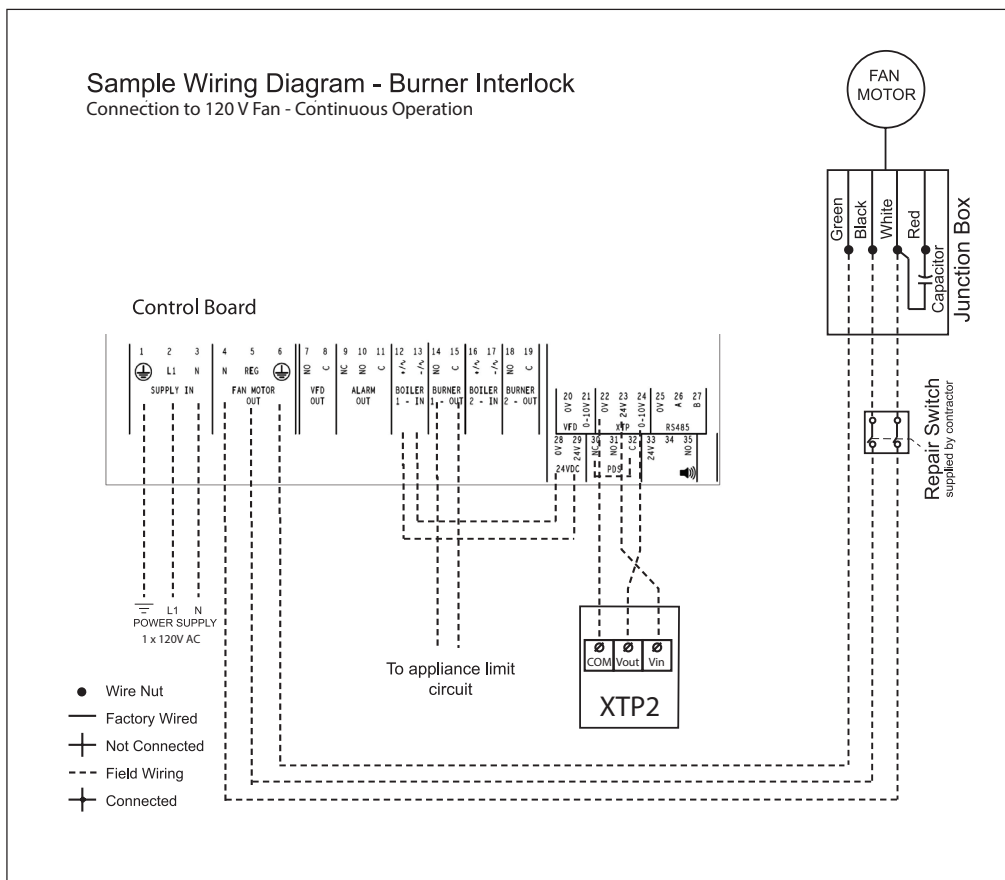

Fig. 7

### 4.3 Intermittent chimney fan operation (120 V)

10 The control can be interlocked with an appliance in two ways:  
It can be interlocked directly with an appliance control, or with a dry set of contacts.

#### Interlock with Burner

Figure 8 shows how an appliance control signal (10-230V AC/DC) is connected to the MEC24:

- Connect the power supply to terminals 1, 2 and 3.
- Connection to the appliance:
  - ▶ Connect the boiler start signal to terminals 12 and 13
  - ▶ The start signal to the burner is now activated by terminal 14.
  - ▶ Connect Neutral to terminal 15.
- To connect the chimney fan:
  - ▶ If using a 1x120V chimney fan, connect it to terminals 4, 5 and 6. Refer to the fan's Installation manual.
  - ▶ If using a 3-phase fan and VFD, connect the VFD to terminals 20 and 21 as shown in Fig. 10 and 11.  
**DO NOT** connect the fan directly to the MEC24 control.
- The XTP-transducer is connected to terminals 22, 23 and 24.

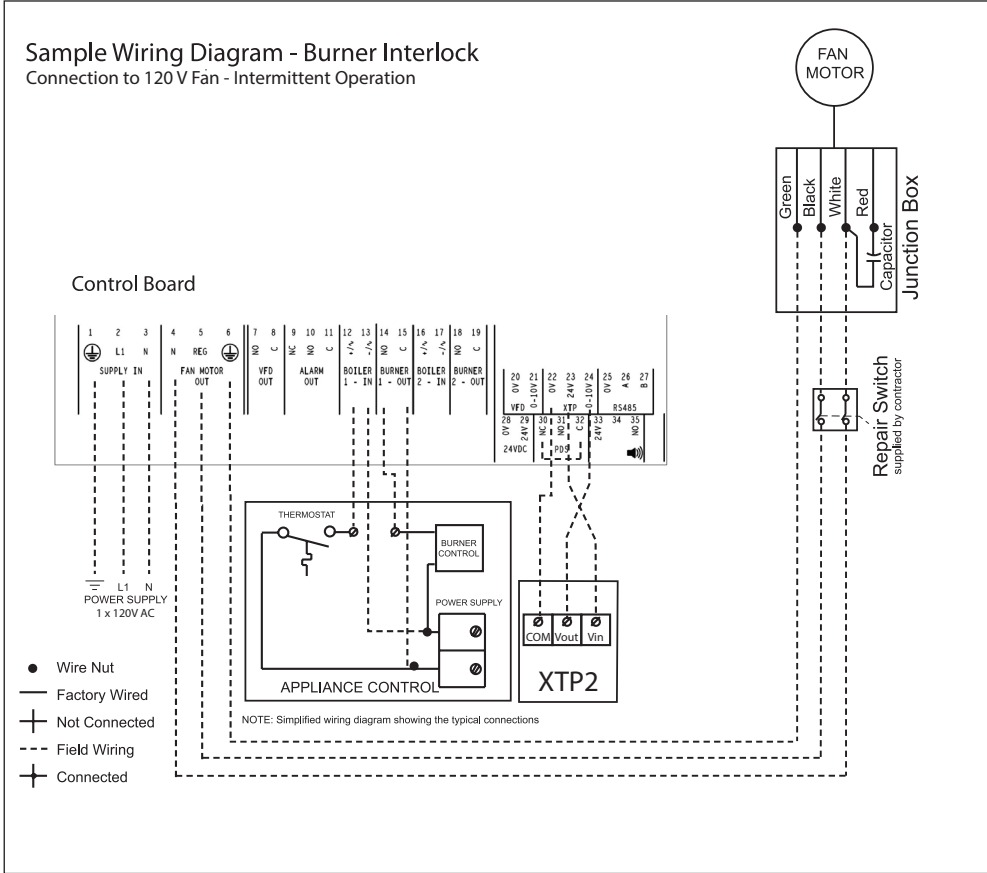

Fig. 8

**Interlock with dry set of contacts**

Figure 9 shows how a dry set of contacts is connected to the MEC24:

- Connect the power supply to terminals 1, 2 and 3.
- Connection to the appliance:
  - ▶ Connect the dry set of contacts to terminals 12 and 13.
  - ▶ Connect the start signal to the burner to terminals 14 and 15.
- To connect the chimney fan:
  - ▶ If using a 1x120V chimney fan, connect it to terminals 4, 5 and 6. Refer to the fan’s Installation Manual.
  - ▶ If using a 3-phase fan and VFD, connect the VFD to terminals 20 and 21 as shown in Fig. 10 and 11. **DO NOT** connect the fan directly to the MEC24 control.

Connect the XTP transducer to terminals 22, 23 and 24

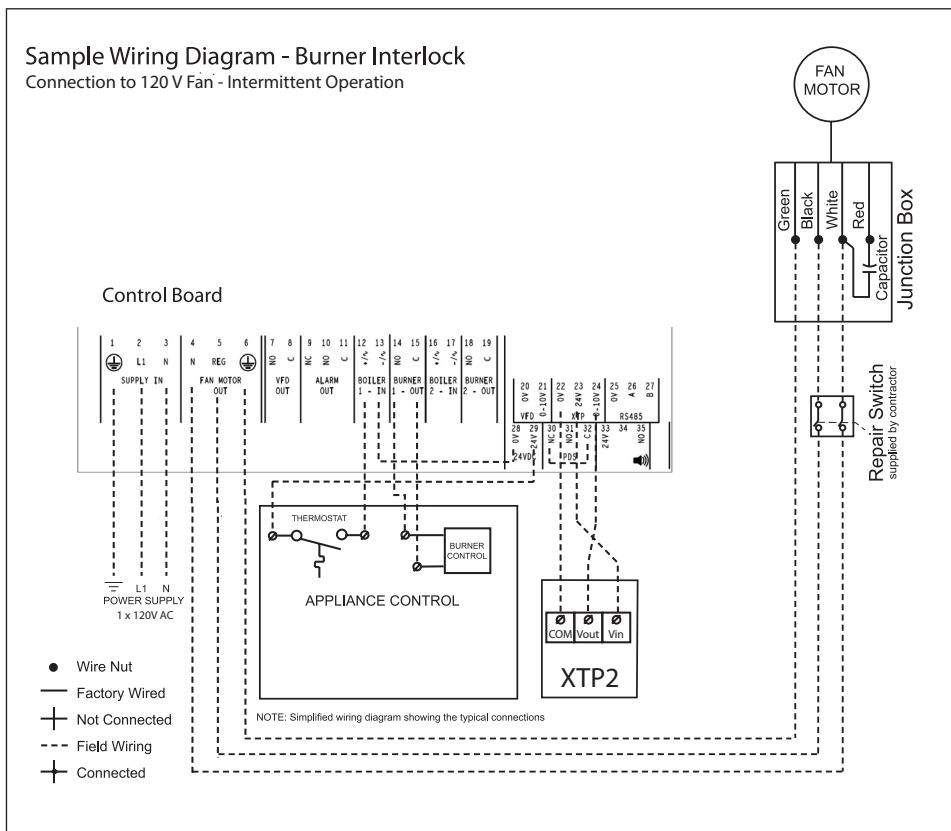

**Fig. 9**

### 4.4 Connection to a variable frequency drive

12

To connect the 3-phase fan and variable frequency drive (VFD), connect the VFD to terminals 20 and 21 of the MEC24. **DO NOT** connect the fan directly to the control. Wire the ABB ACS355 series variable frequency drive according to fig. 10.

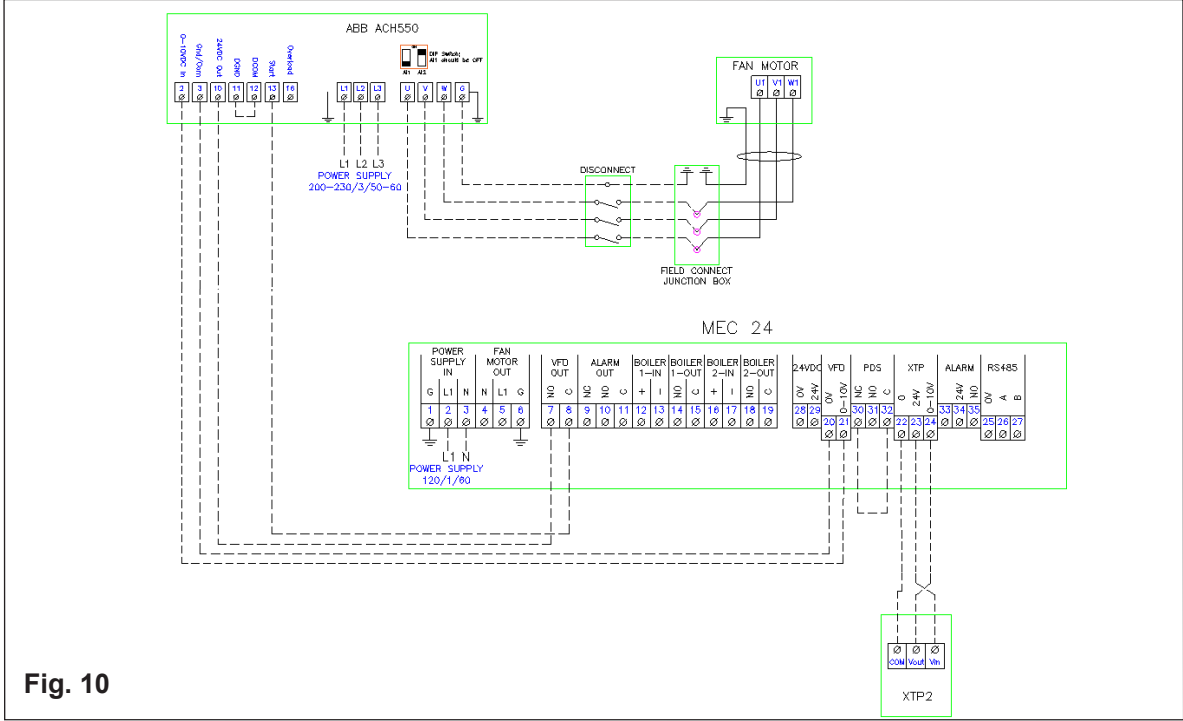

Fig. 10

Wire the EnerveX E-Drive variable frequency drive according to fig. 11.

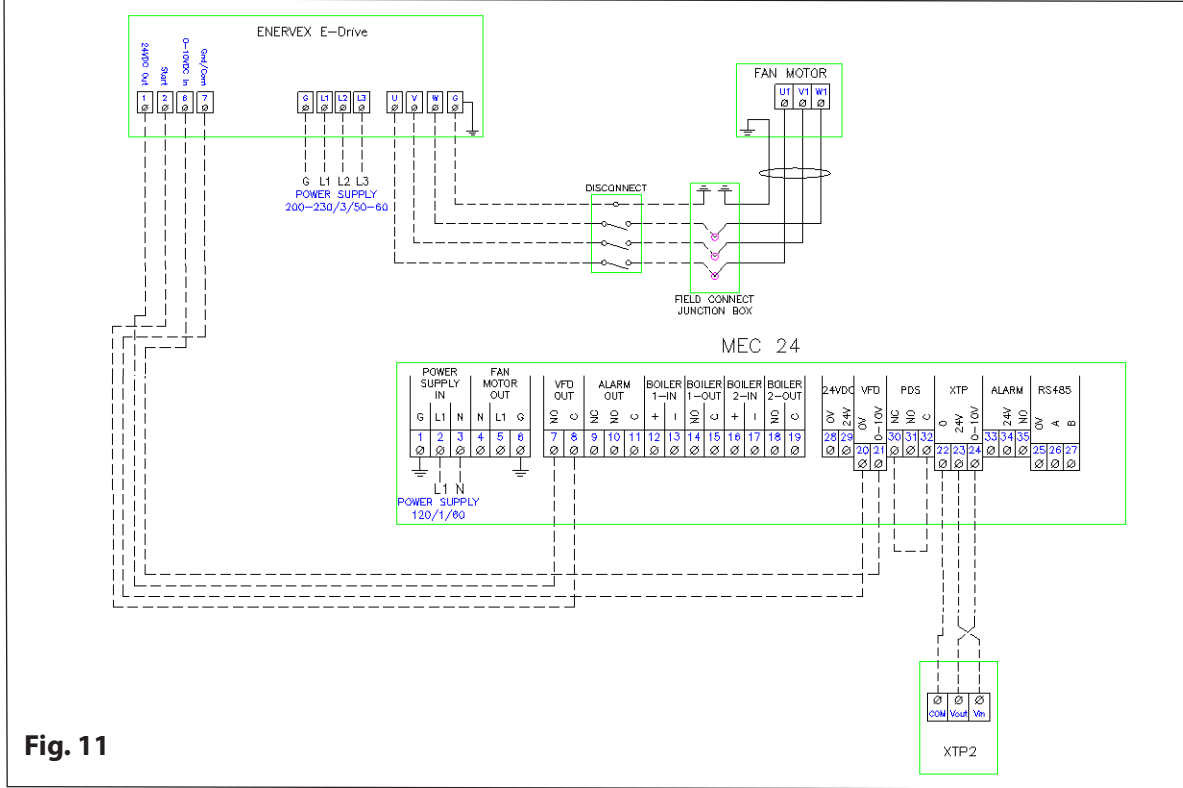
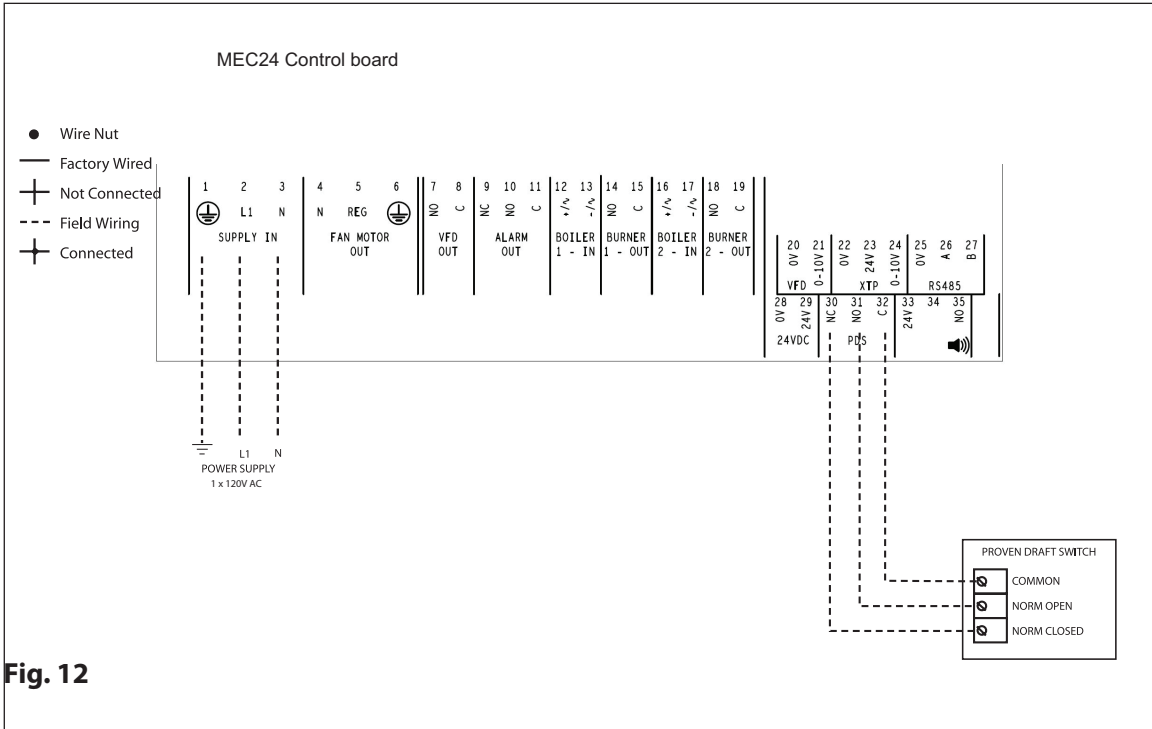

Fig. 11

**4.5 Integrated Proven Draft Switch with external Proven Draft Switch backup**

Fig. 12 shows how to connect a external Proven Draft Switch (PDS) to the MEC24. The external PDS is a backup to the integrated PDS and both must be satisfied by sufficient draft to release the appliance:

- Remove the factory installed jumper over terminals 30 and 32.
- Connect the switch to terminals 30, 31 and 32 as shown on fig. 12.



**Fig. 12**



## 5. Startup and configuration

### 5.1 General

When power is supplied to the control it will go through a start-up procedure to detect and check all components and appliances installed.

### 5.5 Basic control set-up

Once power is turned ON the control can be programmed. Most parameters are programmed at the factory and do not need to be changed. The most common parameters are shown below.

To enter the setup menu, press the "✓" key for more than 5 seconds. The password 3142 must be entered using the up and down buttons, and after that press the "✓" key.

---

#### Menu 11: SET EXHAUST

For setting the draft or exhaust pressure. Although the value, when measured in the field, is negative pressure it shows up as a positive value on the display. The lowest possible value is 0.012 inWC. Most applications require a setting in the range of 0.012 inWC to 0.100 inWC. Atmospheric appliances (Category I) are always in the low range, while all other appliances can be anywhere.

The %-value indicates the relative setting of the total range of the sensor. (The [inWC] units can be changed to [Pa] in the menu 512.)

---

#### Menu 12: EXHAUST OPERATING MODE

The control can operate the fan(s) in either '*continuous*' or '*intermittent*' mode. The mode can be changed via the display in menu 12.

Note! Continuous mode only works if Priority mode is "off" (menu 451)

In '*continuous*' mode the fan operates continuously. During times when the heating appliance(s) is not operating, the fan will still operate although at its lowest capacity. Some exhaust will be pulled through the appliance. The chimney is always primed and there is no real need for pre- and post-purge functions. The energy consumption in this mode is minimal.

In '*intermittent*' mode the fan only operates if at least one appliance is operating. When no appliance(s) is operating the fan shuts down. In this mode, pre- and post-purge functions are very important and must be set. This mode offers the lowest energy consumption.

If a heating system operates constantly, or the time between cycles is very short (less than 5-10 minutes), '*continuous*' mode should be considered. Otherwise, '*intermittent*' mode should be selected.

There is no need to set this value, if the control is used to control the supply of combustion air.

If used with a damper actuator, set for '*continuous*' operation.

---

#### Menu 13: SET EXHAUST PRE-PURGE

When operating in '*intermittent*' mode it is important to set the pre-purge. Pre-purge is the period from when there is a call for heat until the control allows the appliance to start assuming the fan is operating at the proper capacity. The setting can be anywhere from 0 to 1800 seconds.

There is no need to set this value, if the control is used to control the supply of combustion air.

---

#### Menu 14: SET EXHAUST POST-PURGE

When operating in '*intermittent*' mode it is important to set the post-purge. Post-purge is the period from when the appliance shuts down until the control allows the fan to shut down assuming there are no more products of combustion in the chimney system. The setting can be anywhere from 0 to 1800 seconds.

There is no need to set this value, if the control is used to control the supply of combustion air.

## 5.6 Detailed control programming

---

### Menu 362: USB logging

---

The MEC24 can be set to log on a USB-memory stick if the menu 492 is set to "USB". If this is done, two files will be created: one with the alarm log and one with the values of the XTP sensors and 0-10V. The files are .CSV files.

The output format is:

[Unix time], [Exhaust XTP 0-1024], [Intake XTP 0-1024], [Exhaust VFD 0-1024], [Intake VFD 0-1024], [Damper Out 0-1024], [MODS XTP 0-1024]. The value between 0-1024 is a fraction of 10V, meaning that a value of 423 equals 4.13 V.

---

### Menu 365: Firmware upgrade

---

The MEC24 can be firmware upgraded using a USB-memory stick. Insert the USB-memory stick with the firmware in the USB connector on the front of the control. Go to the 362 menu, and select the correct file to be programmed. Press the ✓ button to start the update. The update takes approx. two minutes.

Note! If the programming fails, power off the control. Press the x button and power up the control again. Doing this will reupload the latest working firmware.

## 6. Settings and troubleshooting

16

### 6.1 Troubleshooting

Most terminal connections are monitored for proper operation. LED lights indicate operating status. If a light is lit, it indicates everything is functioning properly while a light out indicates a problem on the circuit it monitors. In addition, fault codes are shown on the display.

The fault codes are:

Display	Explanation
A1 Exhaust Draft Alarm	Insufficient draft pressure. Can be caused by: <ol style="list-style-type: none"> <li>1. Chimney fan does not have enough capacity</li> <li>2. Mechanical or electrical fan failure</li> <li>3. Blocked chimney</li> <li>4. Introduction of excessive dilution air</li> <li>5. XTP sensor not responding correctly</li> </ol>
A2 Power Fault	Indicates there has been a power fault
A3 Exhaust Error	Indicates a disconnected signal from the XTP-Sensor on the exhaust side to the control Can be caused by: <ol style="list-style-type: none"> <li>1. Loose connections</li> <li>2. Faulty XTP-sensor</li> <li>3. Faulty controller</li> </ol>
A4 Start Alarm	Indicates that the control has not been able to release the heating appliance(s) within 15 minutes.
A5 Alarm Override	Indicates alarm has been ignored
A6 Draft Alarm	Missing signal from PDS-function. Indicates a faulty function.
A7 RS485 error	Communication error between MEC24 and a MODBUS unit
A8 Priority	The draft has been insufficient and therefore the control has gone into Priority mode



## 6.2 Settings

Menu	Sub-menu	function	Display	Description	Range	Default
<b>1</b>		<b>Exhaust</b>	<b>EXHAUST</b>			
	11	Draft set point	SET EXHAUST	Adjustment of exhaust setpoint.	2%-95% af sensor	17%
	12	Operation mode	EXHAUST MODE	Continuous or intermittent operation. In intermittent mode the exhaust fan runs only if one or more boiler inputs are active.	Continuous/ Intermittent	Intermittent
	<b>13</b>	<b>Pre-purge</b>	<b>PRE-PURGE</b>	<b>Pre-purge settings.</b>		
	131	Time	TIME	Pre-purge time in seconds	0-1800	0
	132	Operation mode	SPEED MODE	Select variable if the pre-purge should be controlled by the XTP-sensor or have a fixed speed.	Variable / FIX 20-100%	FIX 100%
	<b>14</b>	<b>Post-purge</b>	<b>POST-PURGE</b>			
	141	Time	TIME	Post-purge settings.	0-1800	0
	142	Operation mode	SPEED MODE	Select variable if the post-purge should be controlled by the XTP-sensor or have a fixed speed.	Variable / FIX 20-100%	Variable
	<b>15</b>	<b>Sensor</b>	<b>SENSOR</b>			
	151	Min. pressure	RANGE MIN	XTP minimum pressure in Pa.	-500 – 500 Pa	0
	152	Max. pressure	RANGE MAX	XTP Maximum pressure in Pa.	0 – 1000 Pa	150 Pa
	<b>16</b>	<b>Parameters</b>	<b>PROPERTIES</b>			
	161	Alarm limit draft	ALARM LIMIT	Select the alarm limit of the draft. The value is in % of the set point.	If 167 = "Negative" ->50 - 80 %. If 167 = "Positive" -> 150 - 300 %"	64 % (167 = "Negative") 144 % (167 = "Positive")
	162	Alarmdelay	ALARM DELAY	Select a alarm delay from 0-120 seconds.	0 – 120 s	15
	163	Min. voltage	SPEED MIN	Mimumum speed of the fan	0 – MENU 164	15 %
	164	Max. voltage	SPEED MAX	Maksimum speed of the fan.	MENU 163-100%	100
	165	Xp	EXHAUST Xp	Proportional gain.	0-30	15
	166	Ti	EXHAUST Ti	Integral gain.	0-30	8
	167	Sampling rate	SAMPLING RATE	Set the sampling rate for the PID Loop	1-10	10
	168	Pressure type	PRESSURE MODE	Positive or negative pressure in the stack.	Positive or Negative	Negative
	169	Application	APPLICATION	Sets if the control has to work as Exhaust or Intake	Exhaust / Intake	Exhaust
<b>2</b>		<b>ALARM</b>				
	21	Alarm Status	ERROR	The error is shown here		
	22	Alarm log	ERROR LOG	The last 10 alarms will be saved in the menu.		
	<b>23</b>	<b>Reset</b>	<b>RESET</b>	<b>Selecting "AUTO" will automatic reset the alarm after 15 seconds. If "MAN" is selected, the "X" has to be pressed.</b>	<b>MAN / AUTO</b>	<b>AUTO</b>
<b>3</b>		<b>Service</b>	<b>SERVICE</b>			
	31	Version no.	VERSION	Software version is showed.		
	32	I/O	I/O-VIEW			
	321	BURNER I/O	AUX OUT XXX AUX IN XX	In this menu the status of the boiler I/O is shown. By pressing $\nabla$ the AUX OUT relays can be activated by pressing $\uparrow$ and down. Multiple activations of the $\checkmark$ button will move from relay 1 to 6		
	322	EXHAUST I/O	EXH XTP x.xV OFF EXH VFD x.xV OFF	XTP, VFD and VFD relay status for Exhaust.		
	323	Draft input	DRAFT INPUT ON/ OFF	Draft Input I/O status.		
	324	Alarm relay	ALARM OUTPUT ON/OFF	Alarm relay output status.		
	33	Options	OPTION			
	331	Bearing cycle	BEARING CYCLE	Selecting "YES" will enable a bearing cycle on present fans, if the boilers has not been active for 24 hours.	ON/OFF	ON
	332	Allow prime		Selecting a number from 0-250 will enable the prime function. This allows the boilers to be activated even though no sufficient draft is present.	0-250 s / off	Off
	333	Draft Input Delay	DRAFT INPUT DELAY	The delay before the control goes into Fraft Alarm	0-20 s	0 s
	<b>34</b>	<b>Factory reset</b>	<b>FACTORY</b>	<b>If "YES" is selected, a factory reset will be performed.</b>	<b>YES/NO</b>	<b>NO</b>

Menu	Sub-menu	function	Display	Description	Range	Default
	36	USB configuration	USB CONFIG			
	361	format USB	FORMAT USB	Selecting "YES" will format the USB flash drive. Notice! All data will be erased!	YES / NO	NO
	362	Data Log	DATA LOG USB / INTERNAL	Selecting "USB" will store the alarm log on the USB flash drive, "INT" will store the log in the internal memory.	USB / INT	INT
	363	Save config. file	SAVE CONFIG FILE	Selecting "YES" provides the possibility to select configuration files stored on the USB flash drive.	YES / NO	NO
	364	Load config. file	LOAD CONFIG FILE	Selecting "YES" will download the current configuration to the USB flash drive.	YES / NO	NO
	365	Upgrade firmware	UPGRADE FIRMWARE	This function provides the possibility to upgrade the firmware by means of a USB Stick		
<b>4</b>		<b>User Interface</b>	<b>USER INTERFACE</b>			
	41	Display	DISPLAY			
	411	Language	LANGUAGE	Language.	ENG / FRA / ESP	ENG
	412	Pressure units	UNITS	Pa or inWC units.	Pa / inWC	inWC
	413	LCD backlight	LCD BACKLIGHT	LCD backlight turned on or not. The USE parameter will cause the backlight to be turned on if a button is pressed.	ON / OFF / USE	ON
	414	LCD contrast	LCD CONTRAST		10 – 100 %	50



